

GENERAL INFO

DESIGNED FOR RAINWATER

Single Water Filter Systems for Whole House / Building Applications

The EM1 Series systems provide peace-of-mind throughout the house, reducing taste, odour, chemicals and sediment in your water. This systems protects and prolongs life of appliances throughout your home. Enjoy purified water at every outlet in the house.

The Puretec Ecotrol™ EM1 Series systems are designed for the budget-conscious householder, giving good general purpose filtration. These systems do not require power to operate. Very easy to maintain, just replace the filter cartridge when the taste and odour returns or every 6 - 12 months.

FEATURES & BENEFITS

- New & Improved Integrated rust-proof, anti-flex aluminium wall mount bracket®.
- Designed specifically for rainwater.
- Can also be used on mains water.
- Dual purpose carbon cartridge that removes both sediment and bad taste & odour.
- Peace of mind with whole house filtration.
- Flow rates up to 110 litres/minute.
- Heavy duty housing for reliable whole house protection.
- Low maintenance, no moving parts.
- No chemicals.
- No power required.
- Filter cartridge included.
- Easy to install.
- 10 Year Warranty^.

®Registered Design



EM1-60

10' Single Water Filter System



EM2-110

20' Single Water Filter System

SPECIFICATIONS

Ordering Code:	EM1-60	EM1-110
Size of Residence:	Small to Medium	Medium to Large
Replacement Cartridge:	DP10MP1	DP10MP2
Micron Rating:	10 Micron	10 Micron
Maximum Flow Rate:	60 Lpm	110 Lpm
Min/Max* Pressure:	200 - 875* kPa	
Min/Max Temperature:	0 - 52°C (protect from freezing)	
Connection:	1" BSP [25 mm]	1½" BSP [40 mm]
Warranty:	10 years^	

*Important Note: Use only genuine Puretec replacement cartridge. ^10 year warranty is 1 year parts and labour, plus 9 years parts only. Excludes cartridges. *Micron Rating is nominal. *If pressure exceeds 500 kPa an approved pressure limiting valve must be fitted.*

PRODUCT DIMENSIONS (measurements shown in mm)

EM1-60

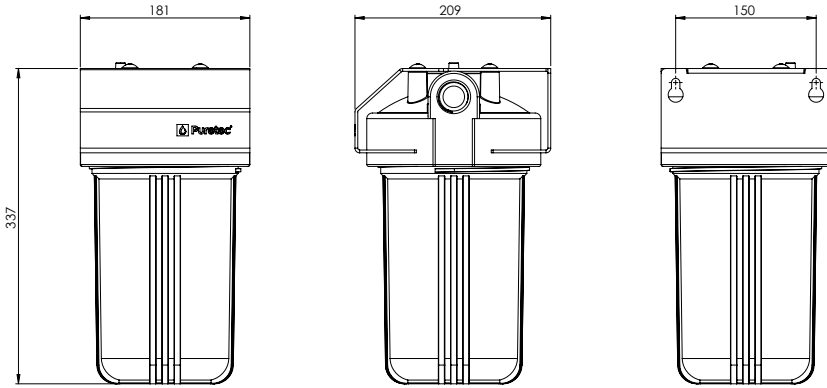

EM1-110

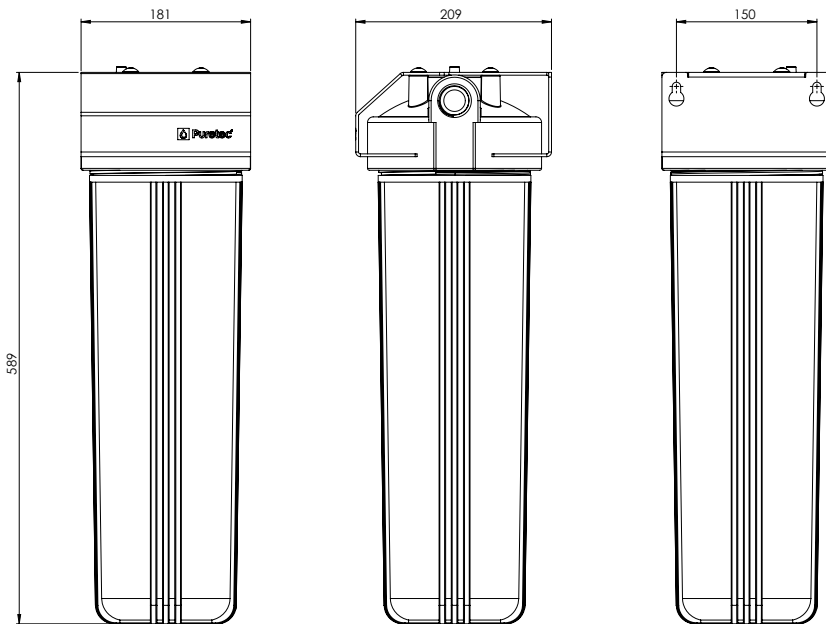

- Note:**
1. No claims can be made based on the specifications and images in this document. The design, technology, colours, features and prices are subject to change.
 2. This document and all its contents are copyright protected. All rights are reserved, particularly alteration, translation and reproduction using electronic systems.
 3. ^Warranties in this document cover parts for the period stated and include cover for parts and labour for the first year where applicable, subject to approval. Plus 9 years parts only.
- Our Water Filtration Specialists can provide you with advice to suit your needs.