

GENERAL INFO

DESIGNED FOR MAINS/TOWN WATER

Whole House Single Water Filter Systems

Enjoy purified water at every outlet in the house. These systems are designed for mains water supplies reducing chlorine, taste & odour, chemicals and sediment in your water for the budget-conscious householder, giving good general purpose filtration.

This system protects and prolongs life of appliances throughout your home and features long-life filter cartridges. It operates on low pressure which is important when multiple taps are used simultaneously throughout the day.

The Puretec WH Series is a logical choice for people concerned about sediment and chemicals in drinking water or when showering and will improve quality of life. The system provides spring-like quality water throughout the house and is affordable for all.

These systems do not require power to operate, and are very easy to maintain, just replace the filter cartridge every 6-12 months or when the taste and odour returns.

FEATURES & BENEFITS

- New & Improved Integrated rust-proof, anti-flex aluminium wall mount bracket[®].
- Peace of mind with whole house filtration.
- Flow rates up to 60 litres/minute.
- Heavy-duty housings for reliable wholehouse protection.
- Low maintenance, no moving parts.
- No chemicals.
- Chlorine, taste & odour reduction.
- Protects and prolongs the life of appliances.
- No power required.
- Filter cartridges included.
- Easy to install.

[®]Registered Design



WH1-30

10' Single Water Filter System



WH1-60

20' Single Water Filter System

SPECIFICATIONS

Ordering Code:	WH1-30	WH1-60
Size of Residence:	Small to Medium	Medium to Large
Taste & Odour Removal Cartridge:	CB10MP1	CB10MP2
Maximum Flow Rate:	30 Lpm	60 Lpm
Min/Max Pressure:	200 - 875 kPa	200 - 875 kPa
Min/Max Temperature:	0 - 52°C (protect from freezing)	0 - 52°C (protect from freezing)
Connection:	1" BSP [25 mm]	1½" BSP [40 mm]
Warranty:	10 years [^]	10 years [^]

*Important Note: Use only genuine Puretec replacement cartridge. [^]10 year warranty is 1 year parts and labour, plus 9 years parts only. Excludes cartridges. *Micron Rating is nominal. *If pressure exceeds 500 kPa an approved pressure limiting valve must be fitted.*

For more information contact your local stockist or visit us at puretecgroupp.com
Australia **1300 140 140** | New Zealand **0800 130 140**

PRODUCT DIMENSIONS (measurements shown in mm)

WH1-30

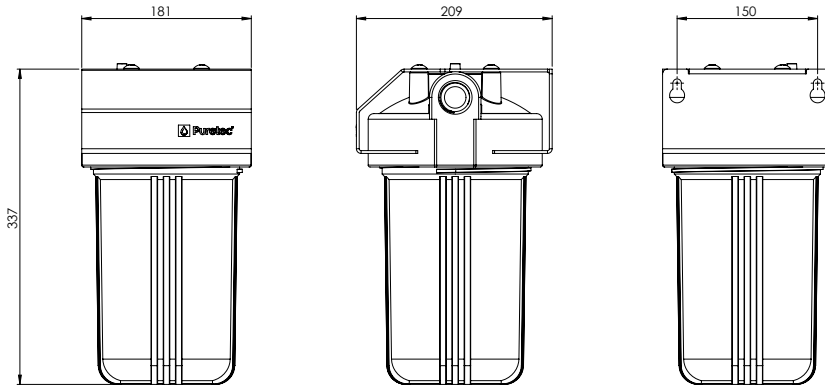

WH1-60

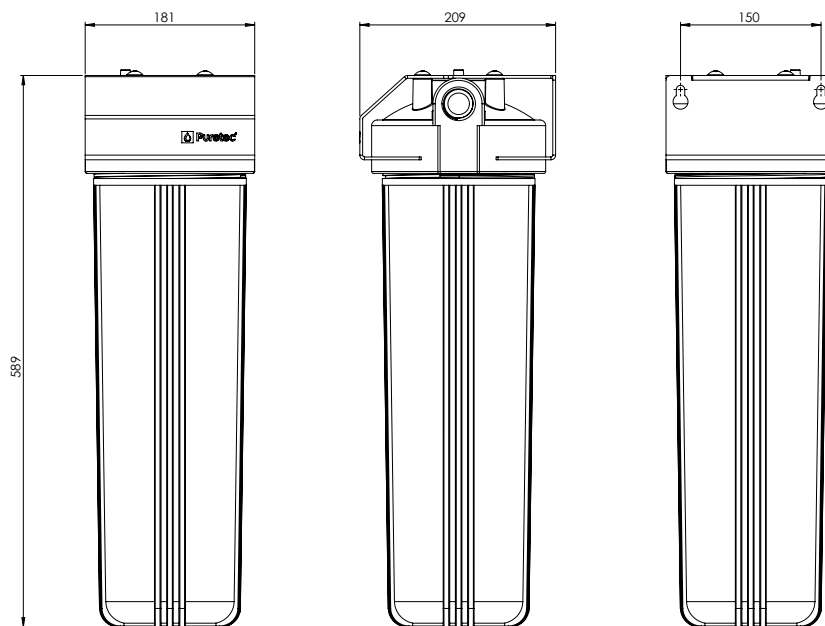

- Note:**
1. No claims can be made based on the specifications and images in this document. The design, technology, colours, features and prices are subject to change.
 2. This document and all its contents are copyright protected. All rights are reserved, particularly alteration, translation and reproduction using electronic systems.
 3. ^Warranties in this document cover parts for the period stated and include cover for parts and labour for the first year where applicable, subject to approval. Plus 9 years parts only.
- Our Water Filtration Specialists can provide you with advice to suit your needs.