

GENERAL INFO

DESIGNED FOR MAINS/TOWN WATER

Dual Water Filter Systems for Whole House / Building Applications

Enjoy purified water at every outlet in the house / building. These systems are designed for mains water supplies reducing chlorine, taste & odour, chemicals and sediment in your water, giving good general purpose filtration. The system provides spring-like quality water throughout the house/building and is affordable for all.

This system protects and prolongs life of appliances throughout your home/building and features long-life filter cartridges. It operates on low pressure which is important when multiple taps are used simultaneously throughout the day.

These systems do not require power to operate, and are very easy to maintain, just replace the filter cartridge every 6-12 months or when the taste and odour returns.

FEATURES & BENEFITS

- New & Improved Integrated rust-proof, anti-flex aluminium wall mount bracket®.
- Large capacity for carbon cartridge.
- Excellent chlorine reduction.
- Peace of mind with whole house filtration.
- Flow rates up to 60 litres/minute.
- Heavy duty housings for reliable whole house protection.
- Low maintenance, no moving parts.
- No chemicals.
- Chlorine, taste & odour reduction.
- Protects and prolongs life of appliances.
- No power required.
- Filter cartridges included.
- Easy to install.

®Registered Design



WH2-30

10" Dual Water Filter System



WH2-60

20" Dual Water Filter System

SPECIFICATIONS

Ordering Code:	WH2-30	WH2-35	WH2-55	WH2-60
Size of Residence:	Small to Medium	Small to Medium	Medium to Large	Medium to Large
Sediment Filter Cartridge:	PX05MP1	PX05MP1	PX05MP2	PX05MP2
Taste & Odour Removal Cartridge:	CB10MP1	CB10MP1	CB10MP2	CB10MP2
Micron Rating:	5 Micron	5 Micron	5 Micron	5 Micron
Maximum Flow Rate:	30 Lpm	35 Lpm	55 Lpm	60 Lpm
Min/Max* Pressure:	200 - 875 kPa			
Min/Max Temperature:	0 - 52°C (protect from freezing)			
Connection:	1" BSP [25 mm]	1½" BSP [40 mm]	1" BSP [25 mm]	1½" BSP [40 mm]
Warranty:	10 years [^]			

*Important Note: Use only genuine Puretec replacement cartridge. [^]10 year warranty is 1 year parts and labour, plus 9 years parts only. Excludes cartridges. *Micron Rating is nominal. *If pressure exceeds 500 kPa an approved pressure limiting valve must be fitted.*

For more information contact your local stockist or visit us at puretecgroupp.com
Australia **1300 140 140** | New Zealand **0800 130 140**

PRODUCT DIMENSIONS (measurements shown in mm)

WH2-30 & WH2-35

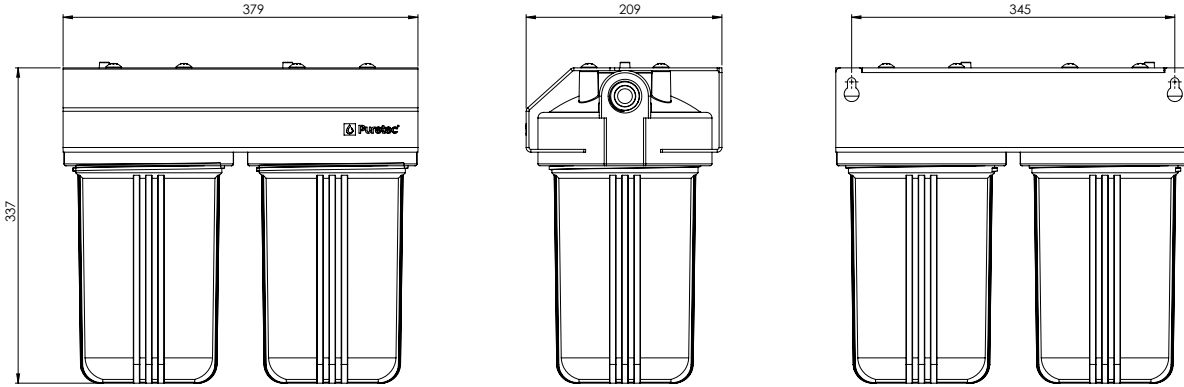

WH2-55 & WH2-60

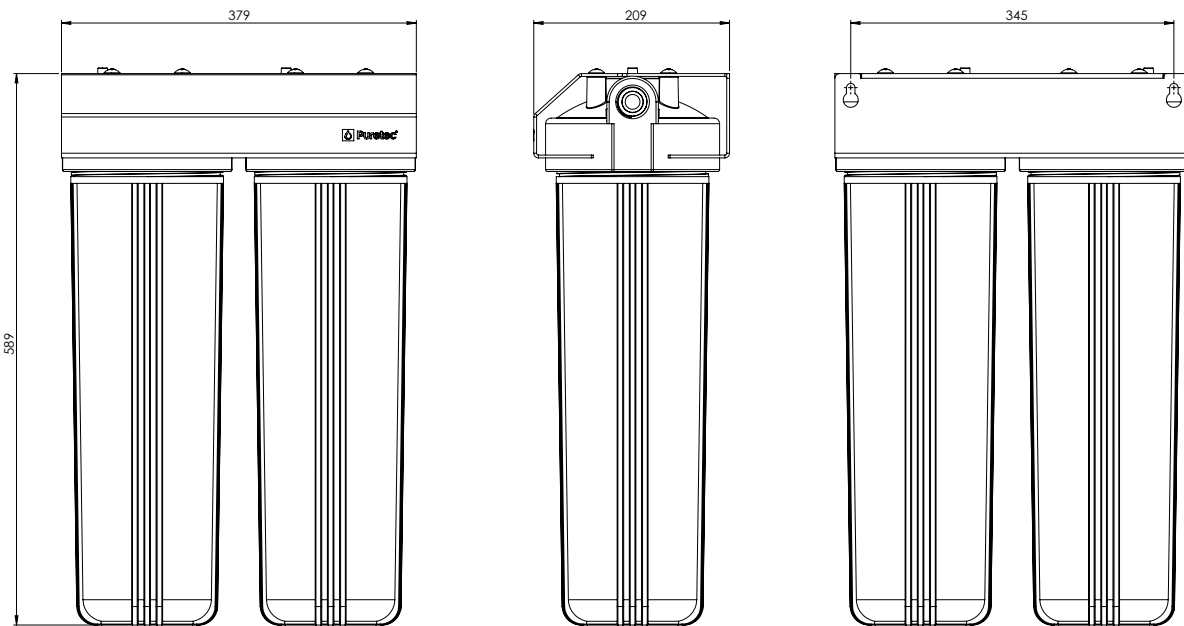

- Note:**
1. No claims can be made based on the specifications and images in this document. The design, technology, colours, features and prices are subject to change.
 2. This document and all its contents are copyright protected. All rights are reserved, particularly alteration, translation and reproduction using electronic systems.
 3. ^Warranties in this document cover parts for the period stated and include cover for parts and labour for the first year where applicable, subject to approval. Plus 9 years parts only. Our Water Filtration Specialists can provide you with advice to suit your needs.